

8

7

6

5

4

3

2

1

NOTE: THIS DRAWING WAS PRODUCED BY COMPUTER, DO NOT UPDATE MANUALLY

REV.	ECN NO.	DESCRIPTION	DESIGN	DATE
A0		新版发行	林飞	2017.09.15

Table:

Circuits	Dimensions(mm)			
	DIM.A	DIM.B	DIM.C	DIM.D
02	2.00	1.00	8.00	4.80
03	4.00	2.00	10.00	6.80
04	6.00	4.00	12.00	8.80
05	8.00	6.00	14.00	10.80
06	10.00	8.00	16.00	12.80
07	12.00	10.00	18.00	14.80
08	14.00	12.00	20.00	16.80
09	16.00	14.00	22.00	18.80
10	18.00	16.00	24.00	20.80
11	20.00	18.00	26.00	22.80
12	22.00	20.00	28.00	24.80
13	24.00	22.00	30.00	26.80
14	26.00	24.00	32.00	28.80
15	28.00	26.00	34.00	30.80
16	30.00	28.00	36.00	32.80

主要技术参数 Main Specifications

线数 (Poles):02 to 16

接触电阻 (Contact Resistance): $\leq 30m\Omega$ 绝缘电阻 (Insulation Resistance): $\geq 1000M\Omega$ 

额定电压 (Rated Voltage):250V AC DC

耐电压 (Withstand Voltage)1000V AC/Minute

温度范围 (Temperature Range):-20℃ ~ +85℃

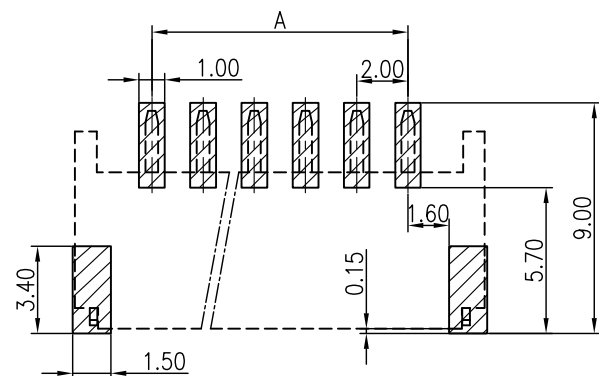
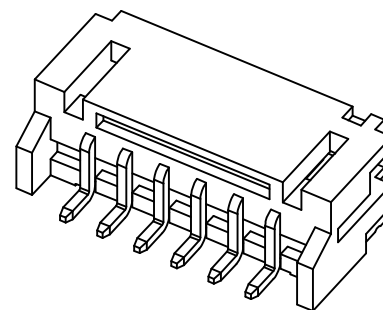
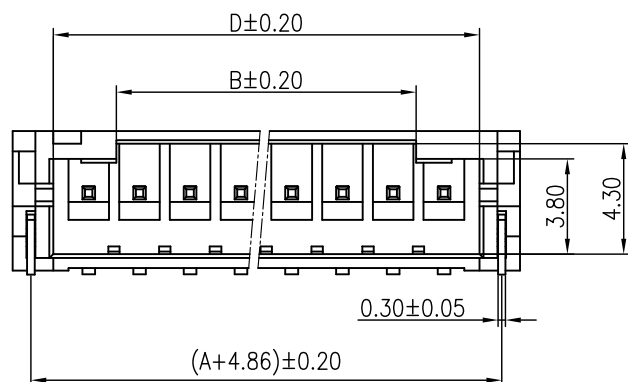
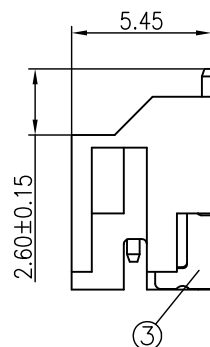
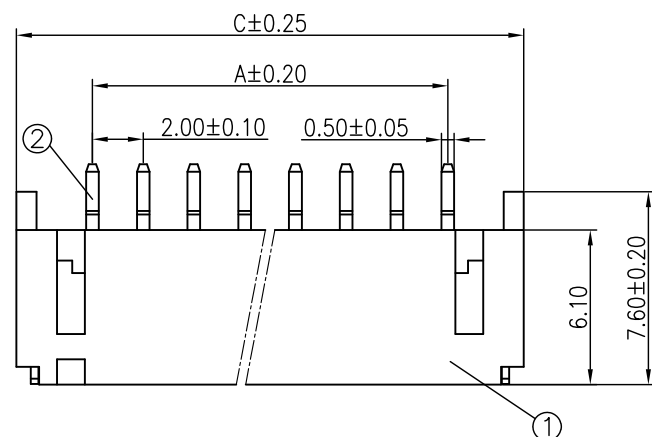

料号说明:

TJ-37 XX SN683-R

Poles:02~16

3	Solder Tab	2 PCS	Brass	Sn-plated
2	CONTACT	2~16 PCS	Brass	Sn-plated
1	HOUSING	1 PCS	LCP	UL 94V-0, COLOR: BEIGE
ITEM	COMPONENT	Q'TY	MATERIAL	FINISH

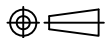
GENERAL TOLERANCE		日期	2017.09.15	UNITS	SCALE	 Alinta Electronics Co., Ltd.			
X.	±0.50	X'.	±5°	mm	1:1				
		核准		REV.	SHEET	品名: A200-SMT-nAW卧贴I型针座系列 料号: 见料号说明 图号: DWG-TJ-683			
.X	±0.30	.X'	±2°	A0	1/1				
.XX	±0.25	.XX'	±1°	SIZE	A4				
		审核			C				
		制图	林飞						

RECOMMENDED P.C.B. LAYOUT  
General Tolerance:±0.05

F

E

D

C

B

A